

Name: _____ Date _____ Partners _____

Lab 8 – INDUCTORS AND L-R CIRCUITS

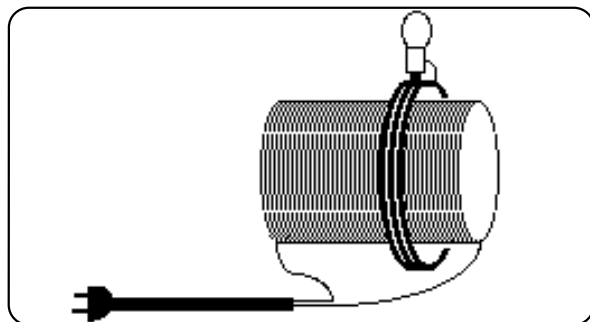

The power which electricity of tension possesses of causing an opposite electrical state in its vicinity has been expressed by the general term Induction . . .

Michael Faraday

OBJECTIVES

- To discover the effect of the interaction between a magnetic field and a coil of wire (an *inductor*).
- To discover the effect of an inductor in a circuit with a resistor and voltage source when a constant (DC) signal is applied.
- To discover the effect of an inductor in a circuit with a resistor and voltage source when a changing signal is applied.

OVERVIEW

You have seen that resistors interact with DC signals (currents or voltages) to produce voltages and currents which can be predicted using ohm's law, $V=IR$. You have also seen that capacitors in RC circuits give predictable currents and voltages according to a different relationship (an exponential relationship) where, for a discharging capacitor in an RC circuit $V(t) = V_0e^{-t/RC}$.

In this laboratory you will be introduced to yet another circuit element, the *inductor*, and the relationship between currents and voltages for an inductor. Like the capacitor, the inductor responds to *changes* in signals. You have seen that a capacitor responds to *changes* in the voltage across its terminals. An inductor responds to *changes* in the current flowing through it.

INVESTIGATION 1: THE INDUCTOR

The purpose of this investigation is to introduce the behavior of coils of wire (inductors) in the presence of magnetic fields and in particular for changing magnetic fields.

You will need the following materials:

- voltage probe and current probe
- small compass
- bar magnet
- one large coil of wire (inductor) (approximately 3400 turns, 800 mH and 63 Ω)
- PASCO 2000-turn detector coil
- 6 volt battery
- alligator clip leads
- switch

Activity 1-1: Magnetic Fields and Inductors, Part I

Magnetic effects are usually described by the existence of a magnetic field. A magnetic field can exert a force on a magnetized object, such as a compass needle. In this activity you will investigate the effect of a magnetic field on an isolated coil of wire (an inductor). One can verify the presence of a magnetic field at a point in space by using a simple compass.

Lay your bar magnet on the sheet below as shown. Use a compass to determine the direction of **B**. Make sure extraneous metal is not affecting the compass. The direction of the compass needle indicates the direction of the magnetic field. Indicate with arrows at the x's the direction in which the compass needle points in the vicinity of the bar magnet. **Try enough of the x's to draw the magnetic field lines.**



One surprising property of magnetic fields is the effect they can have on wires. It is especially noticeable with a coil of many turns of wire, since this will magnify the effect. With your large coil connected to the voltage probe, you will observe the effects of a magnetic field in the vicinity of the coil.

Prediction 1-1: Consider Fig. 1-1 below. Predict the reading of the voltage probe, VP1, when the magnet is

(a) held motionless outside the coil along the axis as shown.

(b) held motionless inside the coil along the axis.

(c) moved quickly from outside the coil to inside the coil, and then back out.

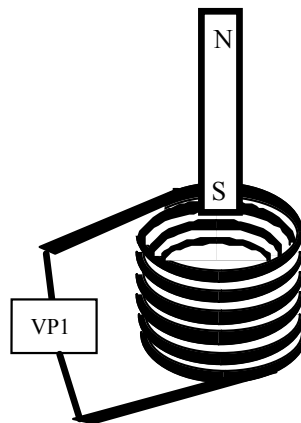

Figure 1-1

1. Connect the **large** coil (inductor) to the voltage probe as shown in Figure 1-1. Make sure nothing else is connected to the coil. (For this exercise, the polarity of VP1 is arbitrary.)
2. Open the experiment file called **Measure Coil Voltage L8A1-1**
3. As illustrated above, hold the bar magnet outside the coil and **begin graphing** the voltage across the coil. Hold the magnet motionless outside the coil for a few seconds. Then move it fairly rapidly inside the coil. Hold the magnet motionless inside the coil for a few seconds. Finally, move it fairly rapidly outside the coil. Then stop graphing.
4. Flip the polarity of the magnet, i.e. turn the bar magnet around. **Begin graphing** and repeat the above sequence.

Comment: Software should be set for 3 minutes of data collection. Voltage must be able to read positive and negative. Sampling rate should be about 750 pts/second



Question 1-1: Summarize your observations. Describe the effects on the coil of wire when you have external magnetic fields that are a) steady (non changing) and b) changing. Do your observations agree with your predictions?

Prediction 1-2: Now consider the case where the bar magnet is held motionless but the coil is moved toward or away from the magnet. Predict what will be the reading by the voltage probe.

5. Choose one of the previous motions of the magnet (N or S pole pointing towards coil, and either moving magnet in or out.) Clear all data. **Begin graphing** the voltage across the coil. Repeat that motion of the magnet. Then, hold the magnet still and move the coil so that the relative motion between coil and magnet is the same.

Question 1-2: Describe your observations. Is it the absolute motion of the magnet, or the relative motion between coil and magnet that matters?

6. Try to change the magnitude of the observed voltage by moving the magnet in and out faster and slower. Do it two or three times on the same display and print out the results.

Question 1-3: What is the relationship you find between the magnitude of the voltage and the rate of change of moving the magnet? Give an explanation if you can.

Activity 1-2: Existence of a Magnetic Field Inside a Current-Carrying Coil.

In the previous activity you used a permanent bar magnet as a source of magnetic field and investigated the interaction between the

magnetic field and a coil of wire. In this activity you will discover *another* source of magnetic field--a current carrying coil of wire.

Prediction 1-3: Consider the circuit in Figure 1-2 in which a coil (an inductor) is connected to a battery. Predict the direction of the magnetic field at points A (along axis, outside of the coil), B (along the axis, inside the coil), and C (outside, along the side of the coil) after the switch is closed.

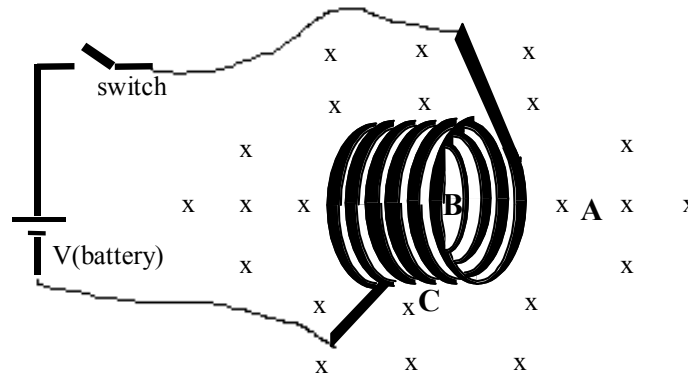

Figure 1-2 Coil connected to battery.

1. Connect the large coil, switch and 6-volt battery in the circuit shown in Figure 1-2.
2. **Close** the switch.
3. Use the compass to map out the magnetic field and draw the field lines on the figure. Try enough locations to get a good idea of the field.
4. **Open** the switch. Do not touch metal when doing so or you may receive a small shock. Flip the polarity of the battery by changing the leads at the battery. **Close** the switch again and note the changes to the magnetic field. Just check a few positions.
5. **Open** the switch.

Question 1-4: Clearly summarize the results. How do your observations compare to your observations of the magnetic field around the permanent magnet? What happened when you changed the battery polarity (direction of current)?

Summary: In this activity you observed that a current-carrying coil produces a magnetic field. The magnitude of the magnetic field is largest in the center of the coil. Along the axis of the coil the direction of the magnetic field is aligned to the axis and points consistently in one direction. Outside the coil, the magnetic field is much weaker and points in a direction opposite to the magnetic field at the coil axis.

The situation can be pictured as shown in Figure 1-3 below. On the left is a coil. On the right is a current-carrying coil and the resulting magnetic field represented by the vectors \mathbf{B} .

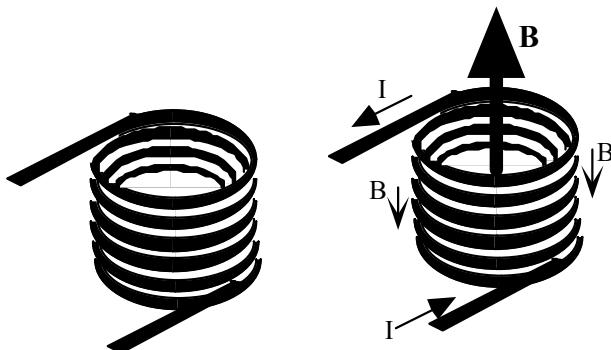

Figure 1-3

Activity 1-3: Magnetic Fields and Inductors, Part II

You have now observed that a current through a coil of wire creates a magnetic field inside and around the coil. You have also observed that a changing magnetic field created by a moving magnet inside a coil can induce a voltage across the coil. In this activity you will observe the circumstances under which interactions between two coils result in an induced voltage.

Consider the circuit shown in Figure 1-4 below, in which the coil on the left is connected to only the voltage probe, and the coil on the right is connected to a battery and a contact switch.

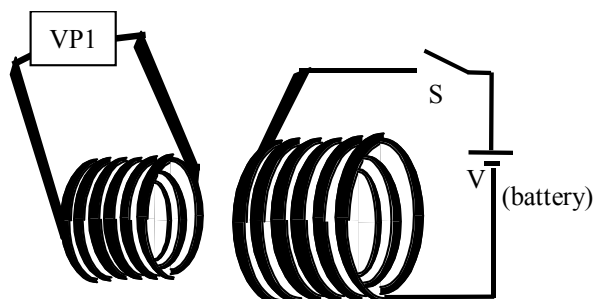

Figure 1-4

Prediction 1-4: Under which of the conditions listed below will you observe a non-zero voltage across the coil that is connected to the voltage probe?

Case I: When the switch is closed awhile, and both coils are held motionless. Circle: yes no

Case II: When the switch is closed awhile, and there is relative motion between the coils. Circle: yes no

Case III: When the switch is left open awhile. Circle: yes no

Case IV: At the moment when the switch goes from open to closed or from closed to open, with both coils motionless. Circle: yes no

Test your predictions.

1. Connect the circuit in Figure 1-4. Connect the large coil to a switch and 6-volt battery, and the small PASCO detector coil to a voltage probe.
2. Open the experiment file **Measure Coil Voltage L8A1-1** if it's not already open.

With Data Studio, you may find it easier to set the voltage axis to a sensitive scale and then prevent automatic re-scaling. To do this, double-click on the graph, click "Axis Settings," and deselect "Adjust axes to fit data."

3. Describe your observations of the coil voltage below. Note: when the switch has been closed and then you open it, you may see a very high frequency, complicated voltage oscillation that we will learn more about in a later lab. For now, concentrate on the lower frequency response.

Case I: Switch closed and coils motionless.

Case II: Switch closed, relative motion between coils.

Case III: Switch open.

Case IV: Switch changes position. (Coils must be close together.)

Question 1-5: Make a general statement about the behavior of coils (inductors) based on your observations. Include in your statement the condition(s) under which a voltage is induced in a coil that is in the vicinity of another coil.

We now want to see what will happen if we replace the battery and switch in Figure 1-4 with an AC voltage source.

4. Remove the battery and switch from the large coil, and instead connect the coil to the output of the PASCO interface (Fig. 1-5). A voltage probe (VP1) should still be connected to the small coil.

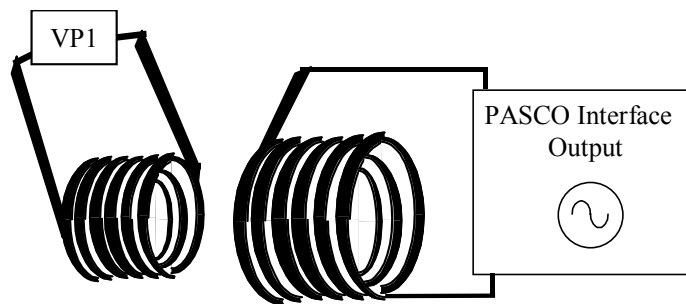

Figure 1-5

5. Open the experiment file **Coil Voltage w/AC L8A1-3**.
6. With the small coil about a foot away, **begin graphing** and slowly move the small coil toward the large coil. When you're finished, leave the small coil approximately in the position of maximum signal, to be ready for the next activity.

Question 1-6: Explain your observations. Comment on the phase relationship between the voltage driving the large coil, and the signal detected by the small coil. (Hint: When is the magnetic field of the large coil changing most rapidly?)

Prediction 1-5: What do think will happen if we leave the coils motionless, and change the frequency of the AC voltage driving the large coil? [Assume that the frequencies are such that the amplitude of the current through the large coil remains constant.]

Test your prediction.

7. Open the experiment file **Coil Voltage vary Hz L8A1-3**. (To avoid clutter, this will only graph the coil detector voltage and not the voltage driving the large coil.)
8. Set the frequency to 1 Hz and begin graphing. Repeat with a frequency of 2 Hz. The two sets of data will be on top of one another. (We use low frequencies so that the "self-inductance" of the large coil does not significantly impede the flow of current.)
9. Move the detector coil away to prove that the signal is really from the large coil.
10. Try larger frequencies if you wish, but be aware that the amplitude of the current in the large coil will not be constant.

Question 1-7: Describe your observations. Did the detected voltage change with driving frequency? How did its amplitude change? Explain why.

Summary: In this investigation you have seen that a *changing* magnetic field inside a coil (inductor) results in an induced voltage across the terminals of the coil.

You saw that such a changing magnetic field can be created in a number of ways: (1) by moving a magnet in and out of a stationary coil, (2) by moving a coil back and forth near a stationary magnet, and (3) by placing a second coil near the first and turning the current in the coil on and off, either with a battery and switch or with an AC voltage source.

In the next investigation you will observe the resistance characteristics of an inductor in a circuit.

INVESTIGATION 2: DC BEHAVIOR OF AN INDUCTOR

Physically, an inductor is made from a long wire shaped in a tight coil

of many loops. Conventionally, the symbol  is used to represent an inductor.

In the simplest case we can model an inductor as a long wire. In previous investigations we approximated the resistance of short wires to be zero ohms. We could justify such an approximation because the resistance of short wires is very small (negligible) compared to that of other elements in the circuit, such as resistors. As you may know, the resistance of a conductor (such as a wire) increases with length. Thus for a very long wire, the resistance may not be negligible.

All 'real' inductors have some resistance which is related to the length and type of wire used to wind the coil. Therefore, we model a 'real' inductor as an 'ideal' inductor (zero resistance) with inductance L in series with a resistor of resistance R . A real inductor in a circuit then can be represented as shown in the diagram to the right, where the inductor, L , represents an ideal inductor. For simplicity, usually we let

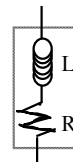

the symbol  represent a 'ideal' inductor while remembering that a real inductor will have some resistance associated with it.

In this investigation you will need the following materials:

- large coil of wire (inductor) (approximately 3400 turns, 800 mH and 63 Ω)
- 6 volt battery
- digital multimeter
- voltage probe and current probe
- two 75-ohm resistors (or close in value to resistance of inductor)
- contact (telegraph) switch
- knife switch

Activity 2-1: Inductors in switching circuits.

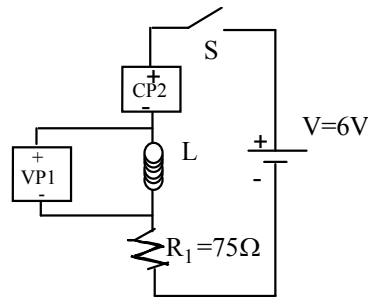

Figure 2-1: LR Circuit with DC voltage applied

Consider the circuit in Fig. 2-1. The coil symbol represents the actual coil you are using, which is an "ideal" inductor in series with a resistor.

1. Using the multimeter, measure the resistance of your inductor and the resistor when not in the circuit.

Resistance of inductor: _____ Ω

Resistance of resistor: _____ Ω

2. Redraw the circuit below, replacing the coil with an ideal inductor in series with a resistor. Label all values. Use 800 mH for the inductance unless the measured value is written somewhere on your coil. Be sure that VP1 is shown across the *inductor/associated resistance* combination (but not across the 75 Ω resistor).

3. In Investigation 1 you observed that a changing magnetic field inside an inductor results in an induced voltage across the inductor. You also observed that a current through the coil causes a magnetic field. Therefore a changing current through an inductor will induce a voltage *across itself*, and this voltage will oppose (but not prevent!) the change.

Calculate the current through CP2 and the voltage VP1 when the switch has been **closed for a long time**:

CP2 current: _____

VP1 voltage: _____

Switch S goes from open to closed to open etc., several times. Predict the current through CP2 and the voltage across VP1 during these changes and **sketch below**. [*Hint: Does the voltage VP1 decay all the way to zero after the switch has been closed for a long time? What if it were connected across an ideal (zero resistance) inductor?*]

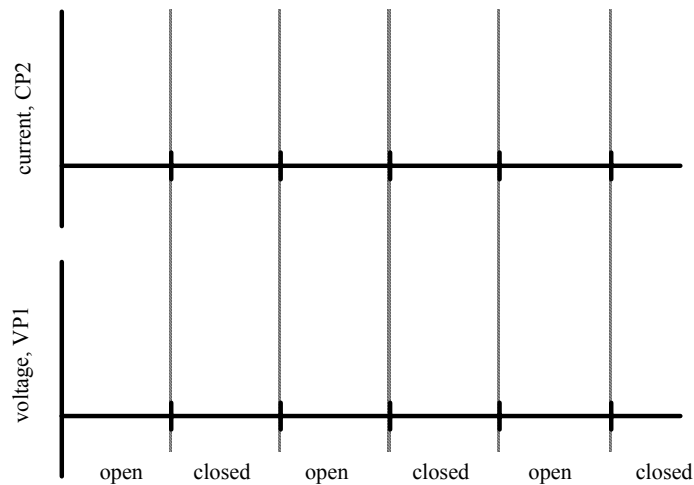

4. Connect the circuit in Fig. 2-1, and open the experiment file called **Switched LR Circuit L8A2-1**. Use a contact switch.

5. Measure the current and voltage as the switch is closed and opened, keeping it closed or opened for about a second each time.

Question 2-1: What do you observe?

6. You should observe the current rising to its maximum value as follows:

$$I = I_{\max} \left[1 - e^{\left(\frac{-t}{L/R} \right)} \right]$$

The time constant L/R is the time it takes the current to reach about 63% (actually $1 - 1/e$) of its final value. Based on your redrawn circuit in step 2, calculate the expected time constant. (What value should you use for R ?)

L _____

R_{total} _____

L/R _____

Predicted time constant: _____ milliseconds

Now use the **Smart Tool** to measure the maximum current on your graph, and the time it takes to reach 63% of that maximum. You will have to spread out the time scale.

Measured time constant: _____ milliseconds.

7. Replace the inductor by a resistor of (at least approximately) a value equal to the resistance of the inductor. Take data again, opening and closing the switch.

Question 2-2: What did you observe? Is there a fundamental difference between inductors and resistors? Explain.

Activity 2-2: Inductors in Switching Circuits, Modified

You may have noticed in the previous circuit that, when the switch is opened, we are attempting to cut off the current instantaneously. When this happens, the current decrease does not follow the normal L/R time constant, and the voltage across the inductor can in principle become arbitrarily large.

To remedy this, we will modify the circuit. Note that the circuit is the same as that for Activity 2-1, except that an extra wire and a switch (S_2) have been added.

Fig. 2-2: modified LR circuit

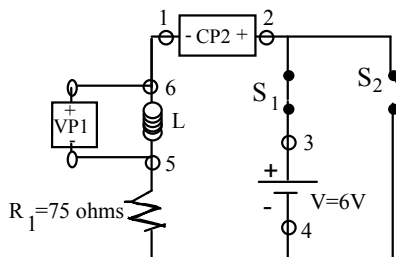

The purpose of switch S_1 is to prevent the battery from burning out when data are not being collected. For the following discussions we will assume switch S_1 is always closed (connected) when taking data. However, **switch S_1 should be open (disconnected) when data is not being collected.**

Question 2-3: The figure on the left below shows the equivalent circuit configuration for Figure 2-2 when switch S_2 is open (with switch S_1 closed). In the space on the right below draw the equivalent circuit configuration when switch S_2 is closed. (Remember, switch S_1 is also closed.)

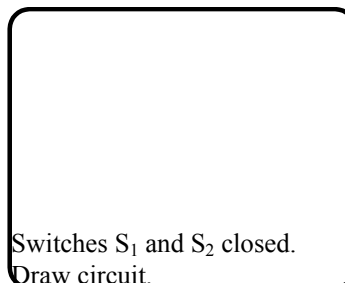
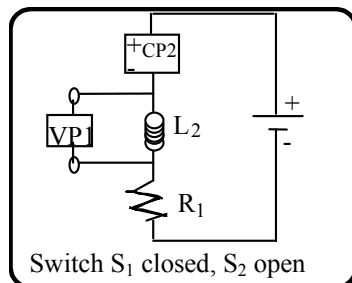

Because the voltage induced across the inductor opposes an instantaneous change in current, the current flow through the inductor just after S_2 is closed must be the same as the current flow through it just before S_2 is closed. (If not, there would have been an instantaneous change in current, which cannot happen.)

Prediction 2-1: Suppose that S_2 has been open for a long time. In the first column of Table 2-1, predict the current in the circuit *just before* S_2 is closed. Now predict in the second column of the table the current *just after* S_2 is closed. Similarly, predict the current in the circuit *just before* S_2 is opened (when S_2 has been closed for a long time). Now predict in the fourth column the current *just after* S_2 is opened.

Table 2-1

	S_2 has been open for a long time	<i>Just after</i> S_2 is closed	S_2 has been closed for a long time	<i>Just after</i> S_2 is open
Current in CP2: (clockwise, zero or counterclockwise)				
Induced voltage ($V_6 > V_5$, $V_5 > V_6$ or $V_6 = V_5$)				

Prediction 2-1, continued: Now consider the voltage across the inductor, L. Based on your predictions for current, will the potential at '6' be greater than, less than or equal to the potential at '5' *just after* S_2 is closed? Write your prediction in the second row of Table 2-1 and explain below.

Will the potential at '6' be greater than, less than or equal to the potential at '5' *just after* switch S_2 is opened? Write your prediction in Table 2-1 and explain below.

Prediction 2-2: On the axes on the next page, sketch your qualitative predictions for the induced voltage across the inductor and current through the circuit for each of the four time intervals. (**Hint:** recall that the voltage across an inductor can change almost instantaneously, but the current through the inductor cannot change instantaneously. *The induced voltage opposes an instantaneous change in current, and, thus, the change in current must take place slowly.*)

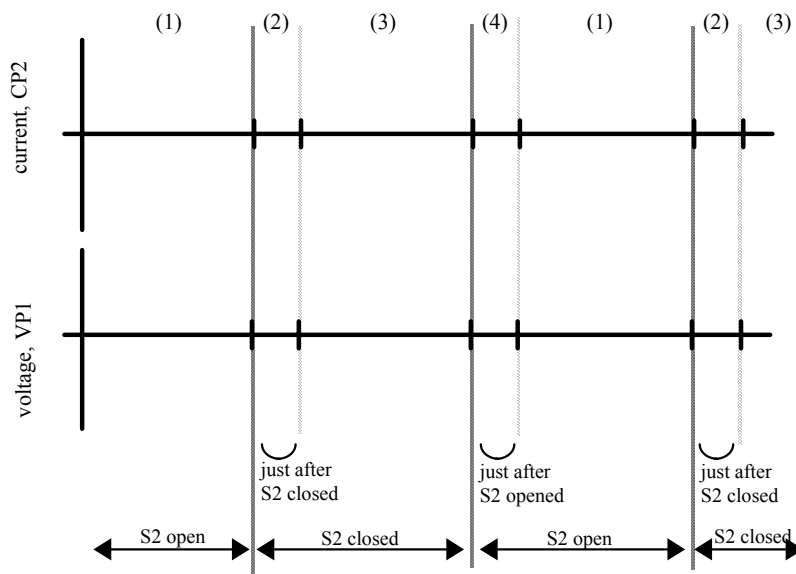

Test your prediction.

1. Connect the circuit shown in Figure 2-2. Use a knife switch for S_1 and a contact telegraph switch for S_2 .
2. Open the experiment file **Switched LR Circuit L8A2-1** if it's not already open.
3. Close switch S_1 and leave it closed for the rest of this step. Measure the current CP2 and voltage VP1 by switching S_2 open and closed. Each time you switch, hold the switch open or closed for about a second.
4. **Print** your graph. After you have collected your data, **open switch S_1** . (This saves the battery from completely discharging while you are not using it.)

Question 2-4: Do your observations agree with your predictions? If not, explain why not. (Is the battery voltage driven all the way to zero by the connection S_2 across it?)