

PEN Experiment Trigger System (Years 2010)

Anthony Palladino¹, Martin Lehman¹

¹*University of Virginia*

July 27, 2010

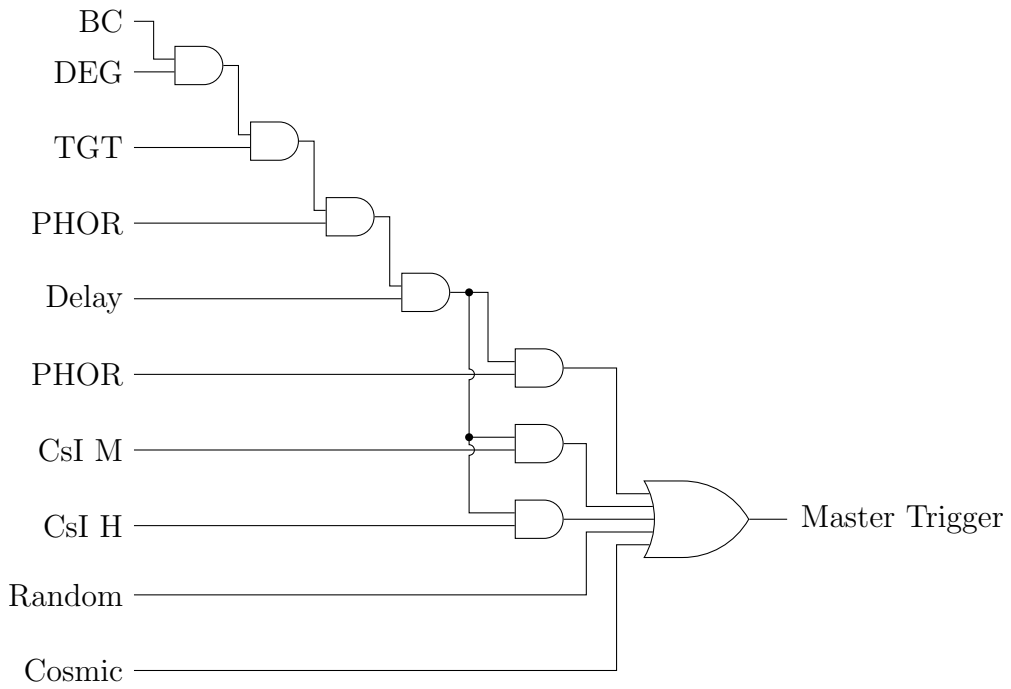

Figure 1: Trigger level 1.

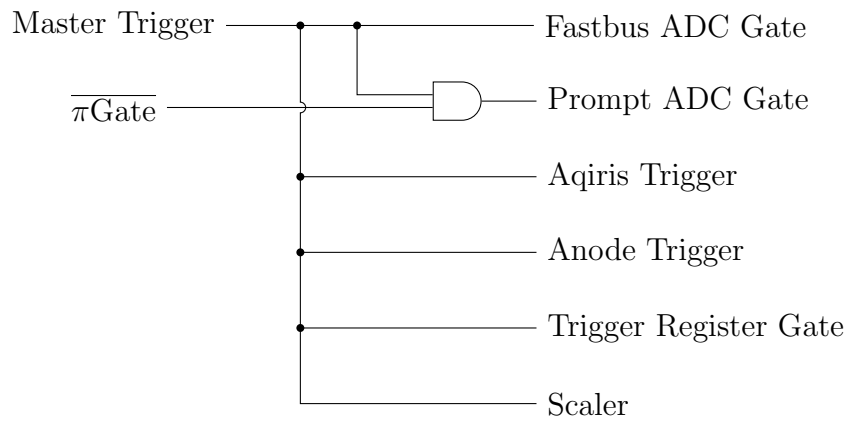

Figure 2: Trigger level 2.

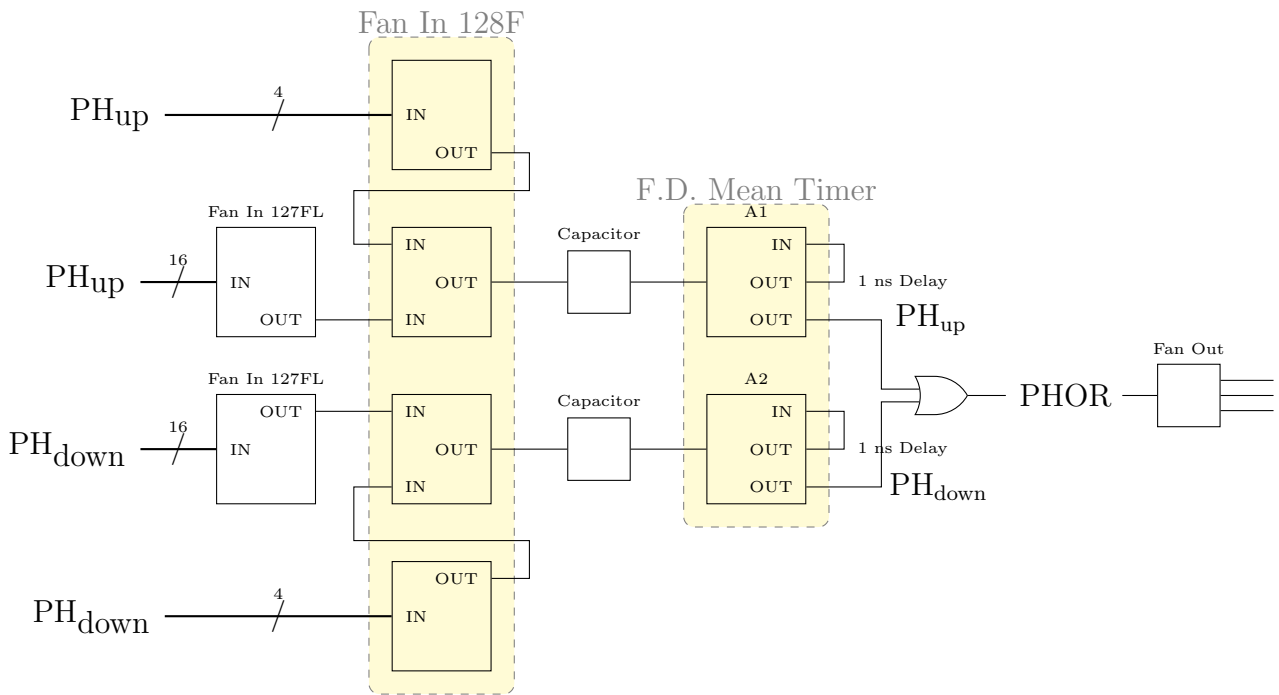

Figure 4: PH Summing.

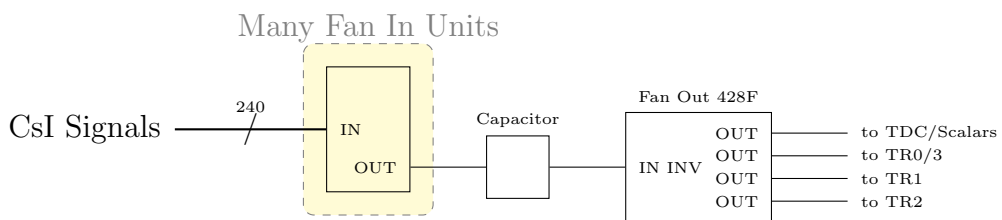

Figure 5: CsI Summing.

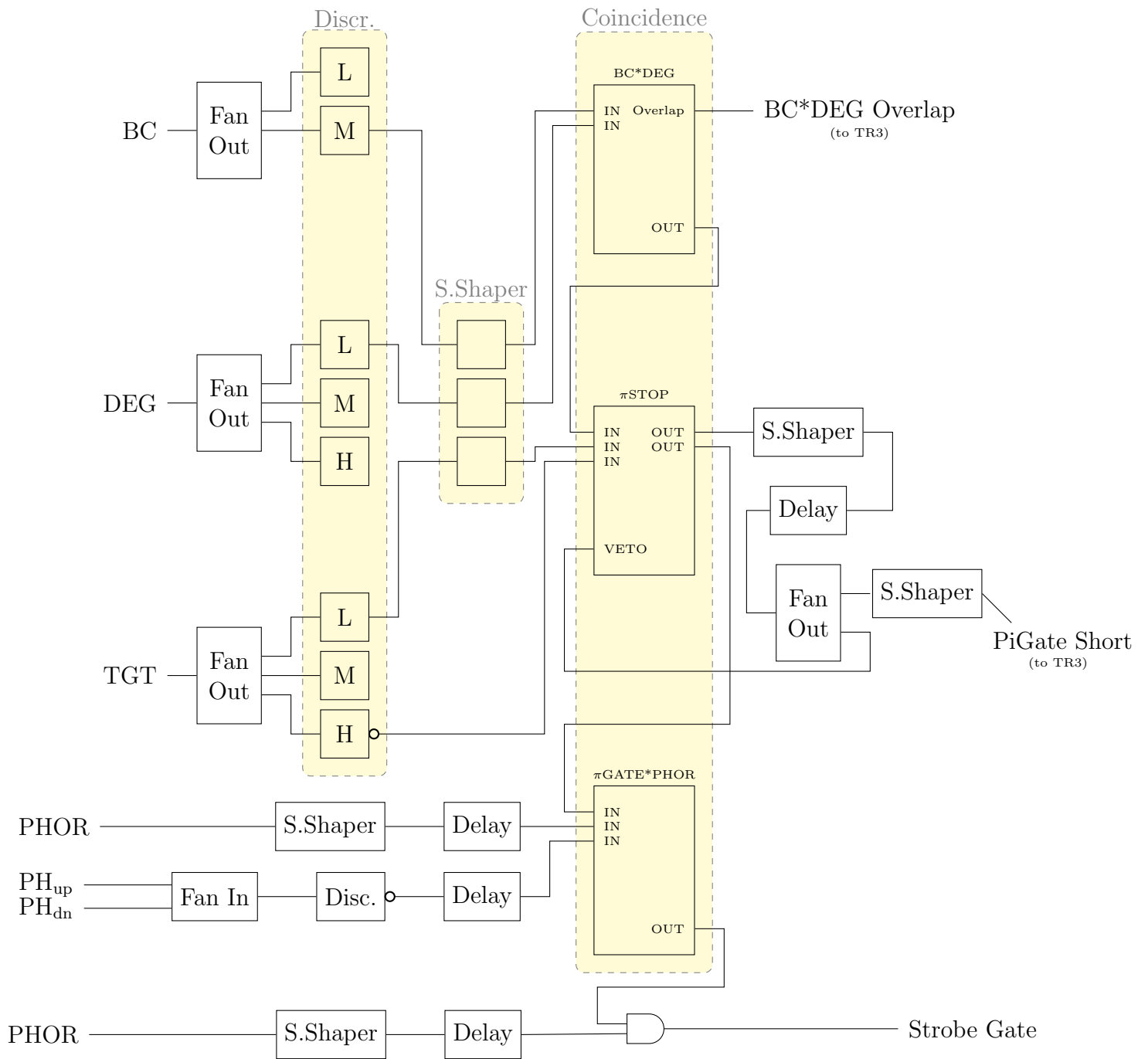

Figure 6: Bottom Level Logic and Strobe Generation.

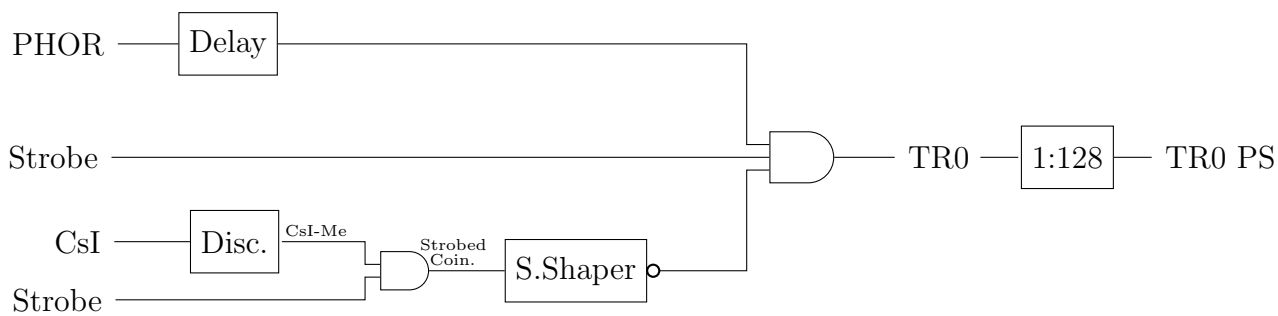

Figure 7: Exclusive TR0.

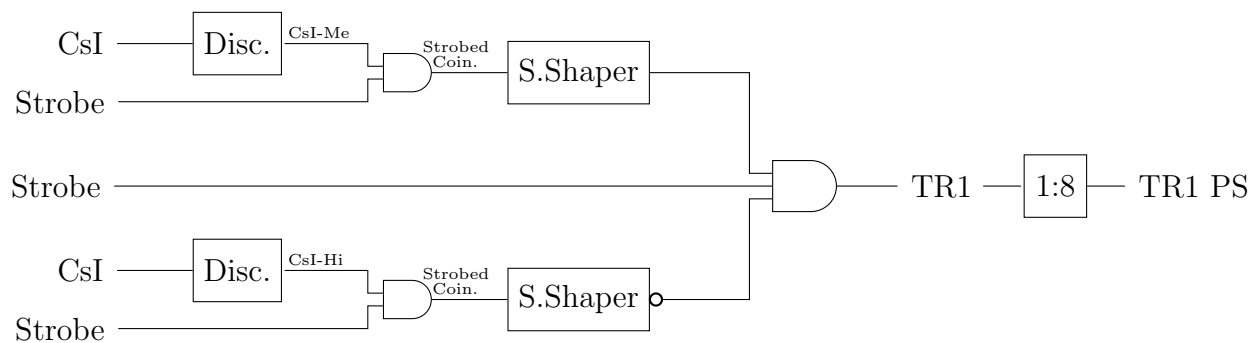

Figure 8: Exclusive TR1.

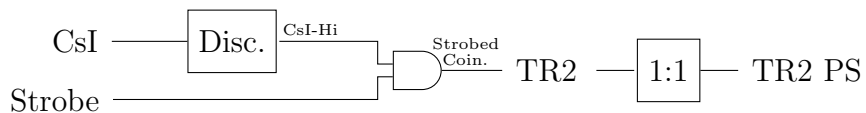

Figure 9: Exclusive TR2.

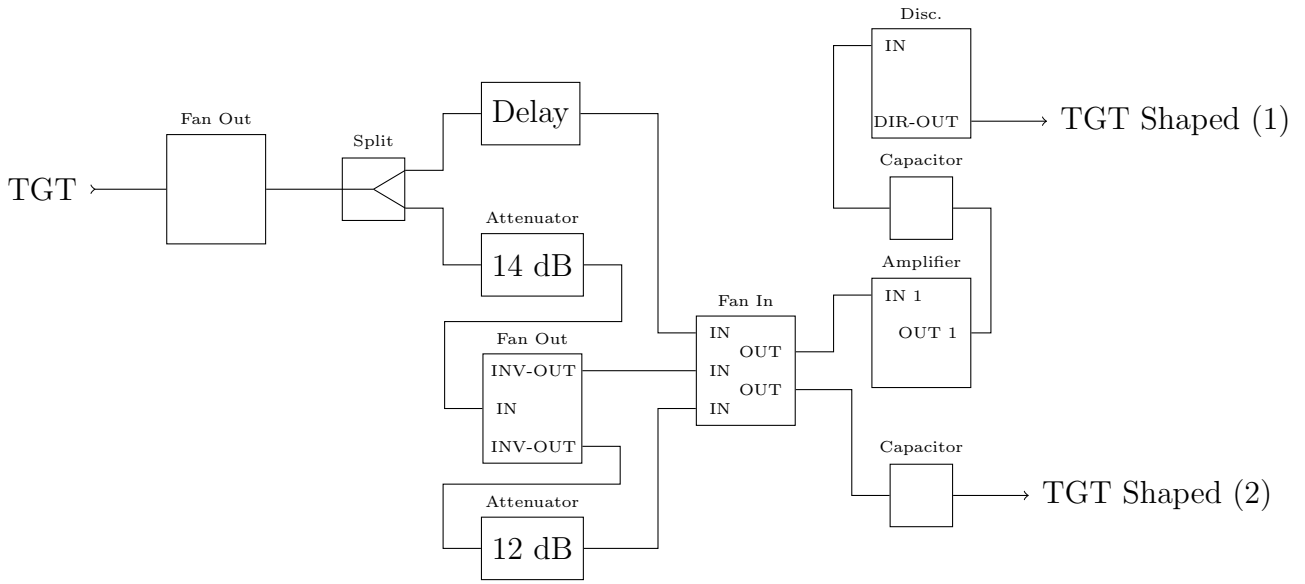

Figure 10: TR3 (part 1) - Target Clip Signal.

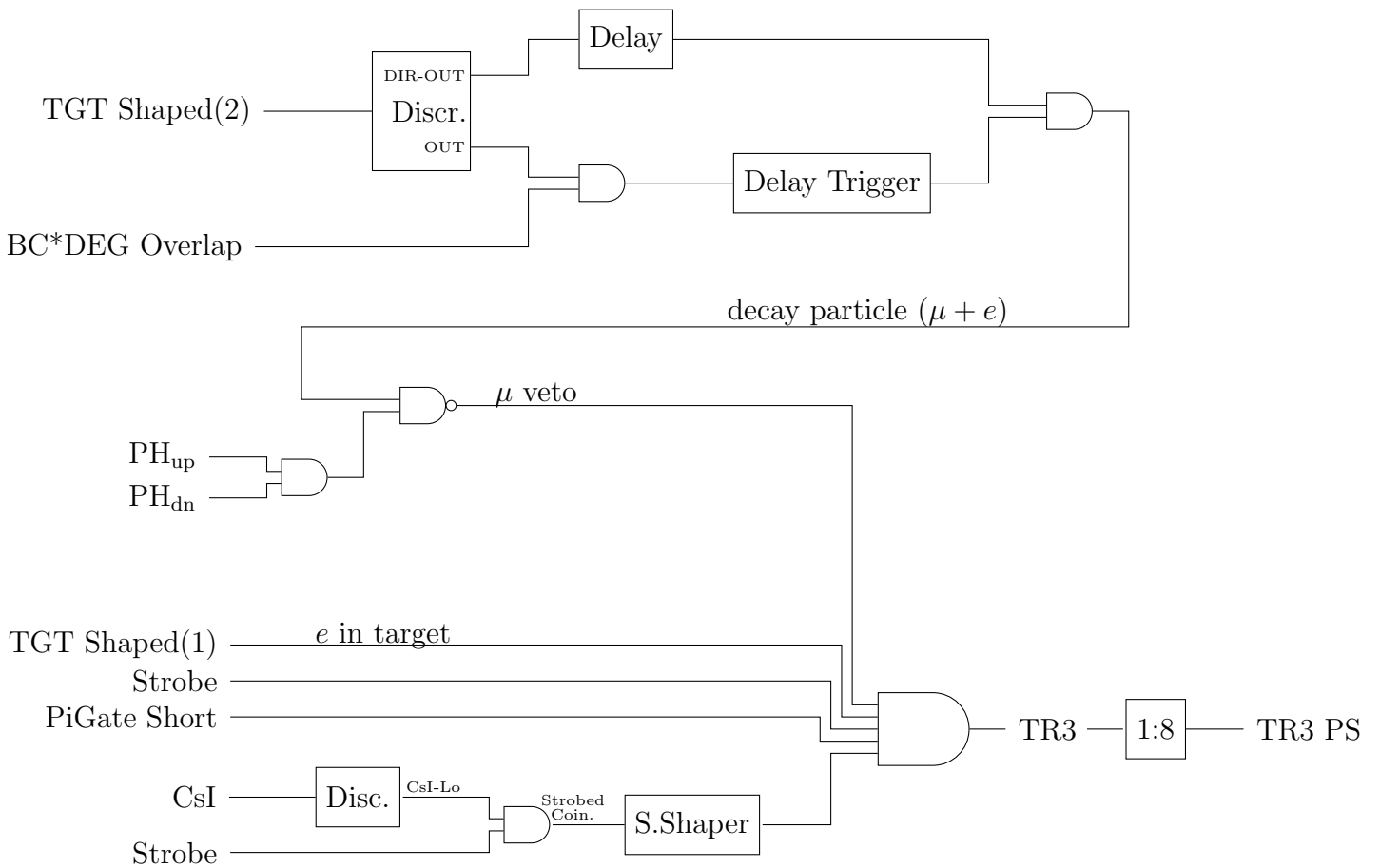

Figure 11: TR3 (part2) - Muon Veto with TR3 Triggers.

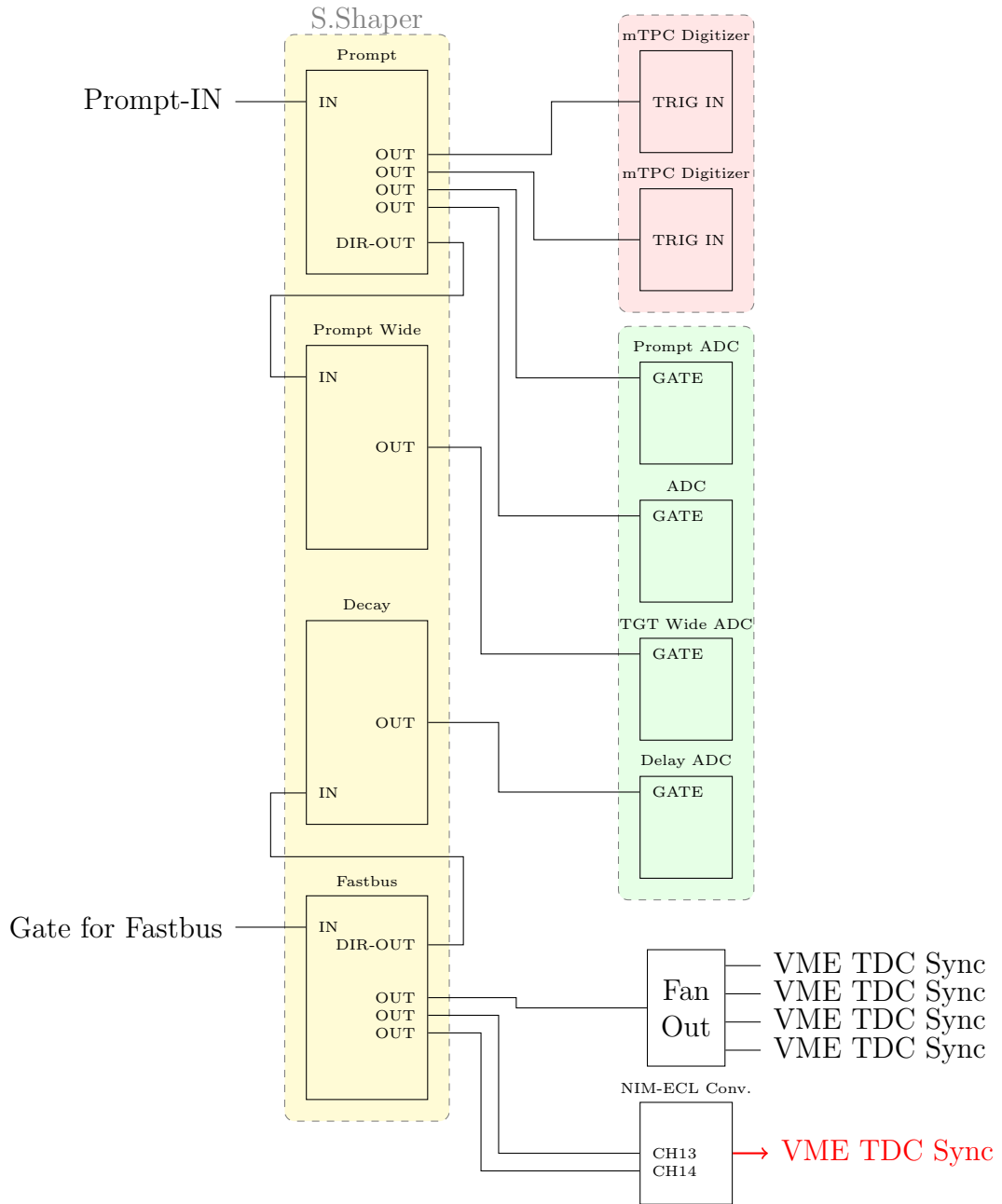

Figure 12: ADC Gate Generation.

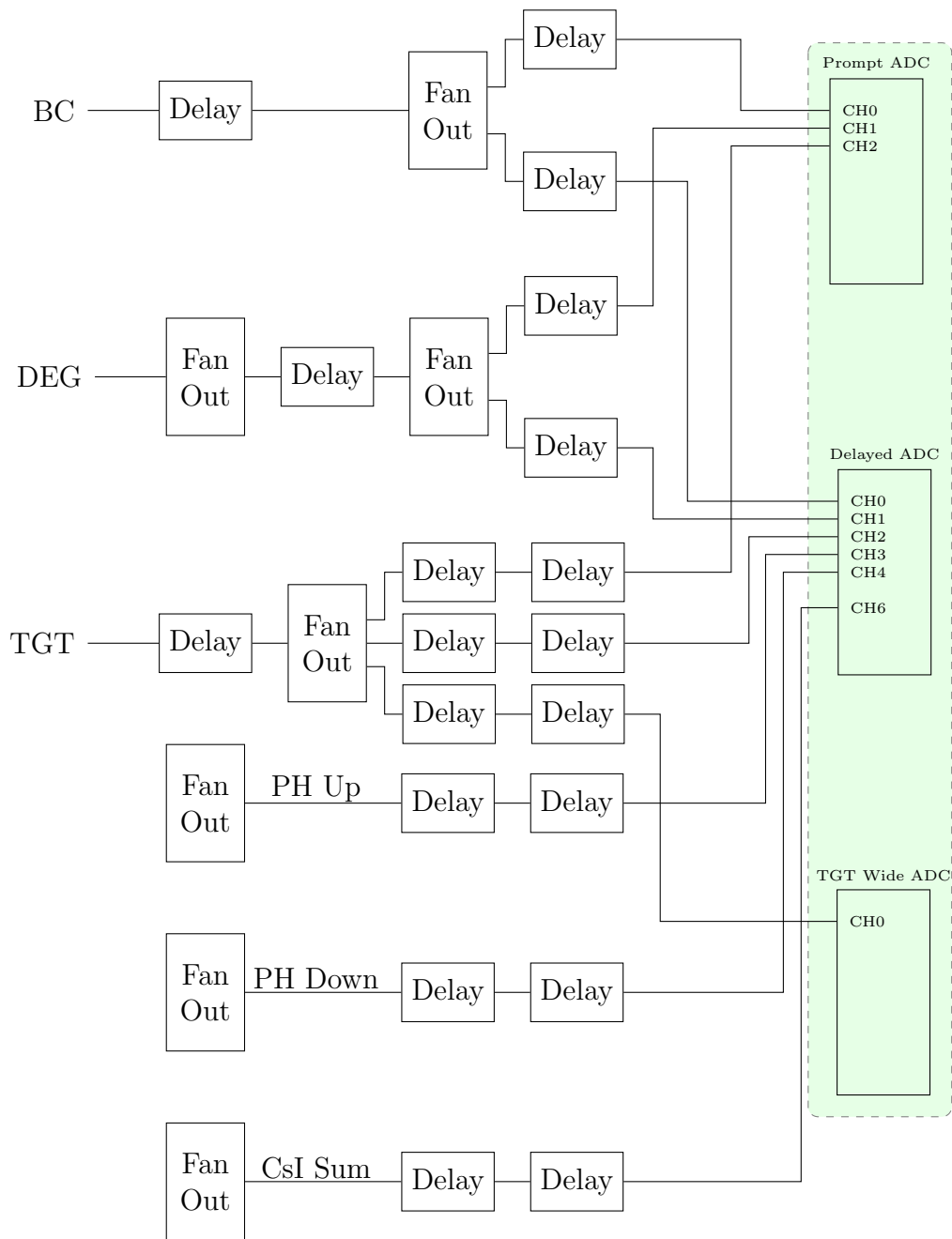

Figure 13: BADC Logic.